

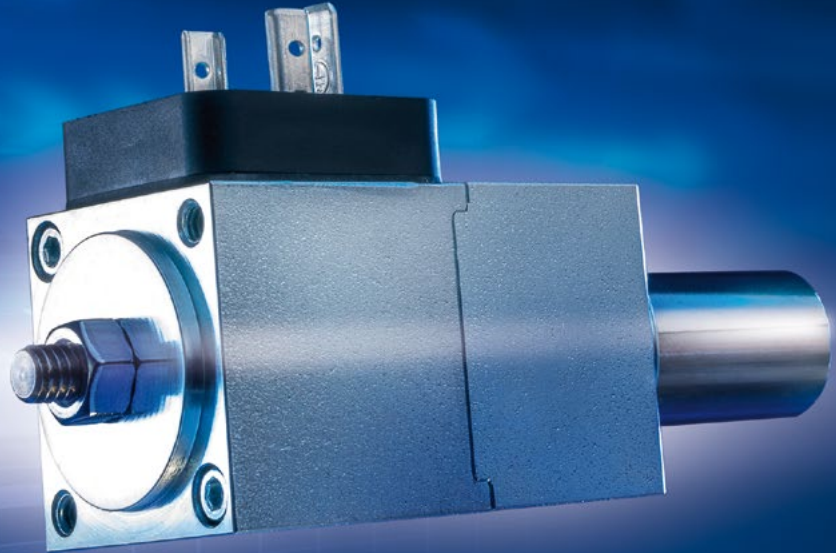

WE MAGNETISE THE WORLD



High Performance Line

Linear solenoids with high performance



INDUSTRIAL MAGNETIC SYSTEMS



We develop solutions!

Kendrion develops, manufactures and markets high-quality electromagnetic and mechatronic systems and components for industrial and automotive applications. For over a century we have been engineering precision parts for the world's leading innovators in passenger cars, commercial vehicles and industrial applications.

As a leading technology pioneer, Kendrion invents, designs and manufactures complex components and customised systems as well as local solutions on demand. Committed to the engineering challenges of tomorrow, taking responsibility for how we source, manufacture and conduct business is embedded into our culture of innovation. Rooted in Germany and headquartered in the Netherlands, our expertise extends across Europe to the Americas and Asia. Created with passion and engineered with precision.

In the business unit **Industrial Magnetic Systems (IMS)** the focus lies on electromagnetic actuators and mechatronic assemblies for applications in power engineering, safety engineering, machine building, automation technology and other industries. With the experience of our traditional brands Binder, Neue Hahn Magnet and Thoma Magnettechnik we are successful in our markets as an industry expert with a high technological competence.

We offer you both customer-specific and standardised products. Our assemblies are based on powerful and reliable single-stroke, holding, locking, spreader, control, rotary, vibratory solenoids and solenoid valves.

We always think in terms of solutions.

Our strength lies in new developments for our customers. Our engineers are specialists for innovative products with optimum technical properties. Furthermore, we develop mechanical assemblies, modern drive electronics and sensor systems to your requirements.

Our products are manufactured in Germany at the parent companies Donaueschingen and Engelswies as well as in the USA, China and Romania. This ensures efficient project management and a needs-oriented delivery for our internationally operating customers.

By means of segmented production areas we can implement both small quantities and large series with an optimum degree of automation.

We guarantee top quality.

All products are tested and developed in compliance with the norm DIN VDE 0580 for electromagnetic devices and components or according to industry-specific standards of our customers. In many cases our products are tested and certified by external associations, among others according to the CSA, VdS and ATEX guidelines. Our quality management system is certified according to DIN EN ISO 9001, and our environmental management system fulfils the norm ISO 14001.

With our subsidiaries in Austria, Italy, the USA, China and our worldwide distribution network we are your ideal partner on site.

Kendrion – We magnetise the world

www.kendrion.com



Success

Solution

Business Strategy

- Innovation
- Branding
- Solution
- Marketing
- Analysis
- Ideas
- Success
- Management

- Innovation
- Branding
- Solution
- Marketing
- Analysis
- Ideas
- Success
- Management

SOCIAL NETWORK



Sep Oct Nov Dec

High Performance Line

The fast-acting linear solenoids excel by an enormous stroke density and a flexible modular system.

These square solenoids are used wherever large forces, short switching times and high efficiency with limited installation space are required. They fulfil the special requirements when used in high voltage circuit breakers and railway door lockings as well as in general actuating functions in automation and safety engineering.

The mode of operation of the solenoid is based on the force exerted on ferromagnetic bodies in the magnetic field. Electromagnets transform electric energy into mechanical energy.

Basically the stroke movement takes place from the stroke starting position to the stroke end position (active direction of movement), while the armature reset is accomplished by external forces, e.g. by spring, weight or magnetic forces (passive direction of movement).

The fast-acting linear solenoids are actuators in which the force of an electromagnetic field is used to perform a longitudinal movement. The stroke limitation can be set by hand for every application. The solenoids can be installed in any position, but the force transfer should be in axial direction only.

All products are manufactured and tested according to DIN VDE 0580/07.2000

The fast acting solenoid in the Standard variant is IP40 protected. The variant LHP035 is also available in IP54 thanks to an additional bellow and sealing ring.



Excels by

- High force
- Compact design
- Modular system



Applications

- Energy technology
- Railway technology
- Automation engineering
- Safety engineering



Accessories

- Connector with or without rectifier
- Fork head with or without ES-bolt



Integrated return spring

In this product line the reset can optionally be performed by an integrated return spring.

The solenoid armature is reset to the starting position.

Fast-acting linear solenoid Series LHP

Thanks to the optimum ratio of iron to copper, the maximum force is achieved in a limited space. The housing consists of two parts, allowing a modular design of different voltage, power and stroke variants.

LHP035

Edge dimension 35mm
Standard version



LHP025

Edge dimension 25mm

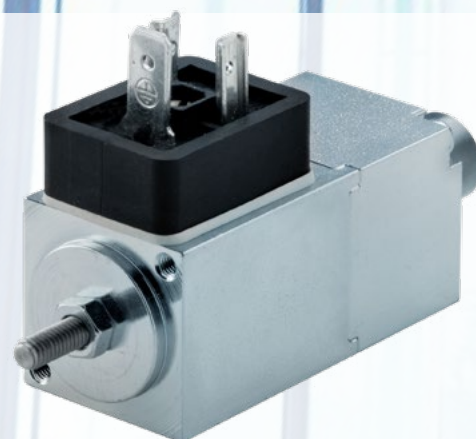

Fast-acting linear solenoid LHP035053

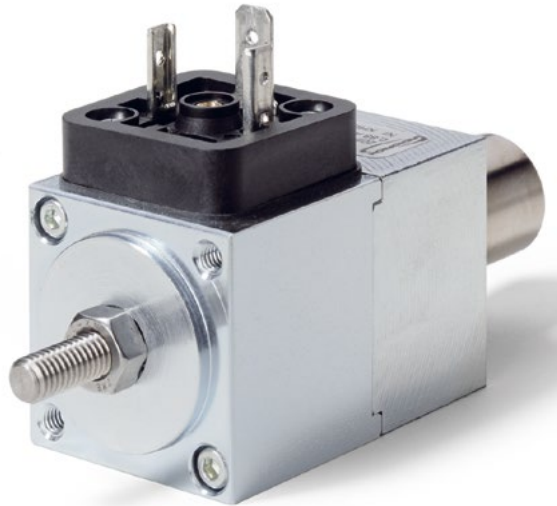

The **LHP035053** is a linear solenoid in closed design with an edge dimension of 35 mm. The series is preferably used for smallest installation volume and high force requirements. The fast-acting linear solenoid can be operated pulling or pushing; the stroke movement is achieved by electromagnetic force from stroke start position to stroke end position. The retraction is effected by an optionally integrated return spring.

The mounting is provided at the front end. The modular design allows to equip the LHP035053 with further options, see options for LHP035053. The solenoid can be mounted in any position; the force transfer is axial. The coil voltage of the standard variant is 24V DC. Other voltages are available on request. The device is provided with lead wires or a connector plug.

Dimension Drawing

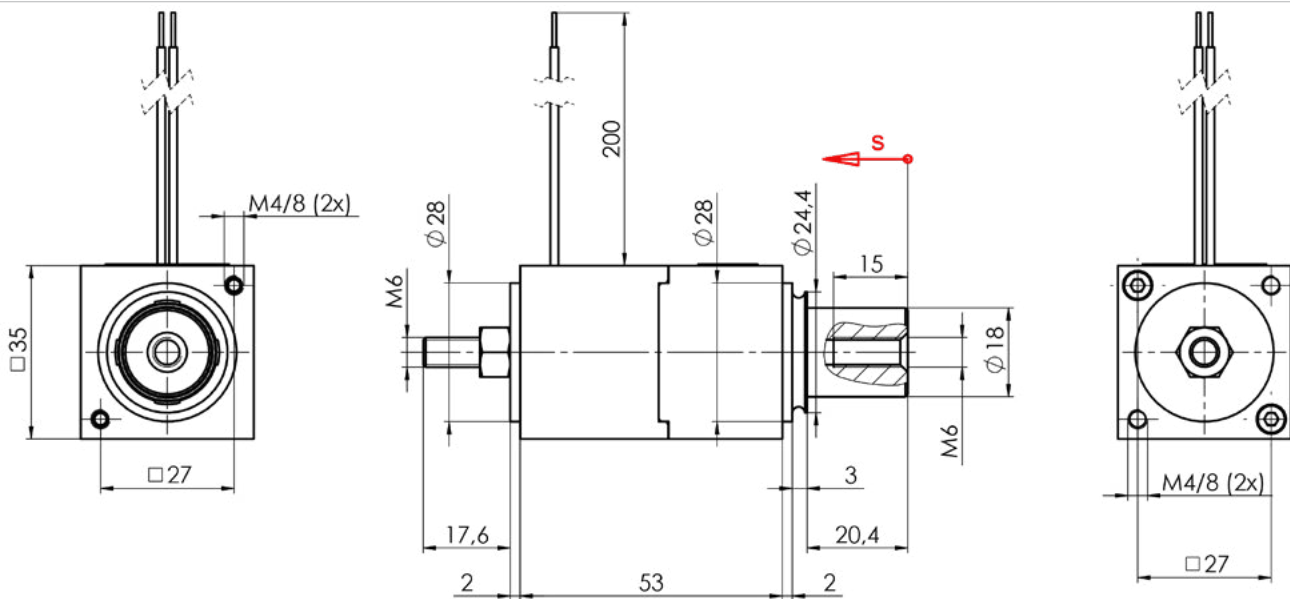

Technical Data

Type	LHP035053															
Duty cycle [%]	100				40				25				5			
Stroke <i>s</i> [mm]	5	10	15	20	5	10	15	20	5	10	15	20	5	10	15	20
Response time [ms]	107	109.5	137.5	143.5	90.5	107.2	124	141	99	107	159.5	177	92.5	107	159.5	177
Release time [ms]	49	64	82	93	40.2	56.4	74.5	88	39	58.5	78.5	85	46.4	58.5	78.5	85
Stroke movement [Ncm]	13	11	11.2	9	20	20	19.5	19	23	23.5	25.5	25	42	47.5	55.5	54
Rated power [W]	20				39.5				57.5				173.5			
Armature weight [kg]	0.11															
Solenoid weight [kg]	0.45															
Thermal class	F															



Information of the possible adjustments to your application are available on request
+49 771 8009 3770 or sales-ims@kendrion.com

Stroke Force Curves

The power indicated is reached at 90% of the rated voltage. The solenoids can be installed in any position, but the force transfer should be in axial direction only. The values for the duty cycles are reference values and apply for rated voltage, warmed-up condition and load with 70% of the magnetic force of the device.

LHP035053 (Stroke 5 mm)

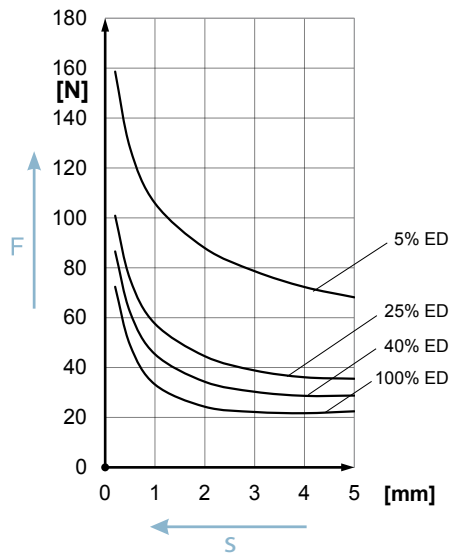

LHP035053 (Stroke 10 mm)

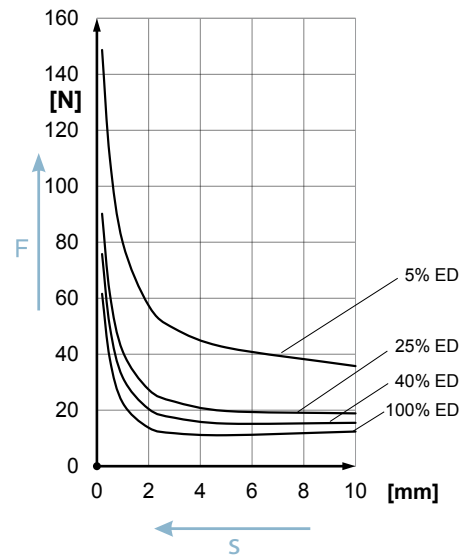

LHP035053 (Stroke 15 mm)

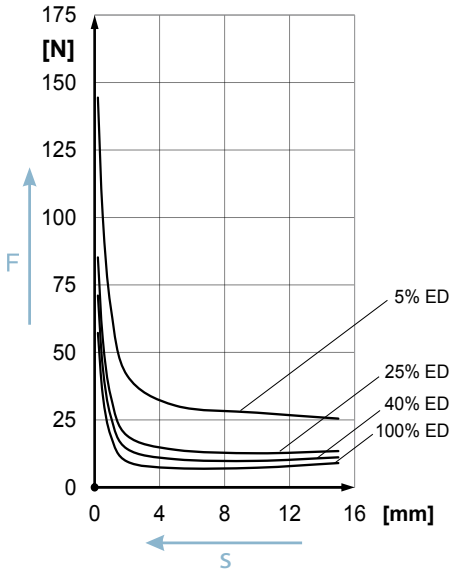

LHP035053 (Stroke 20 mm)

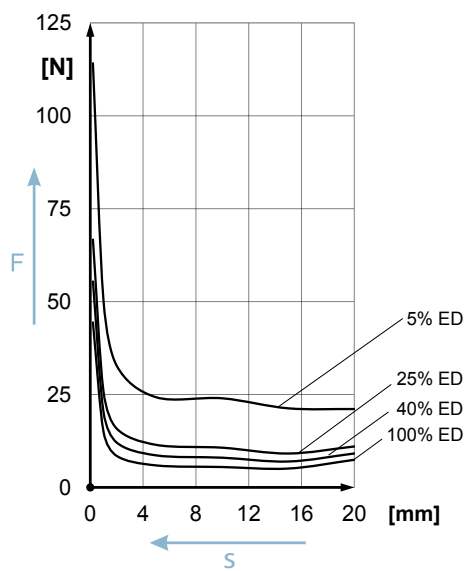

Options for the LHP035053

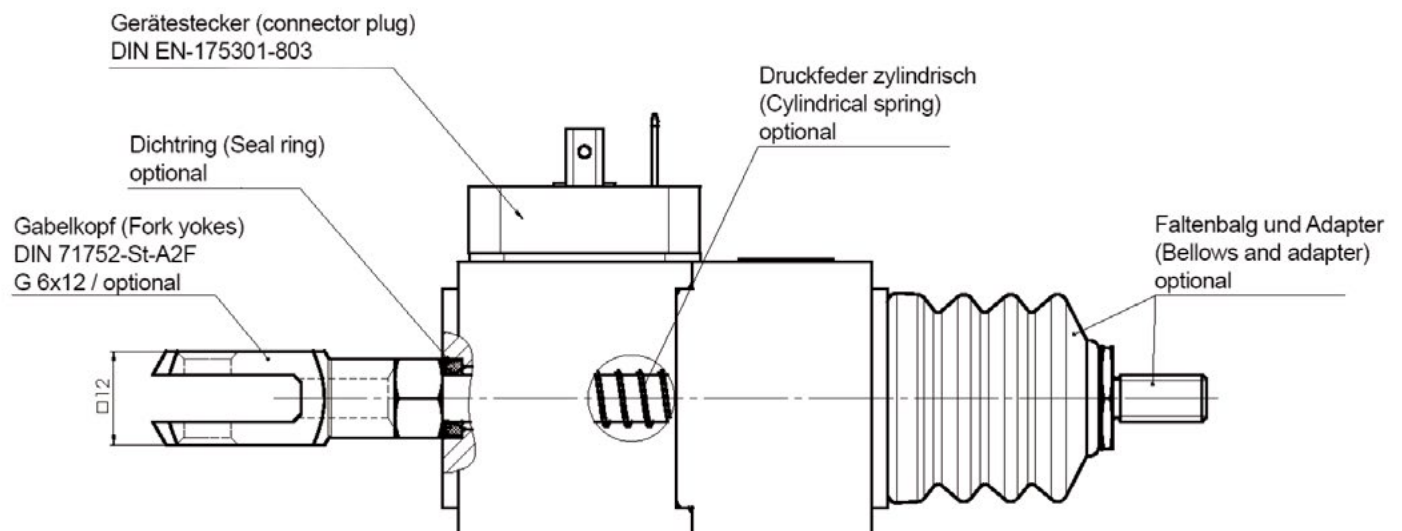

Fast-acting linear solenoid LHP025055

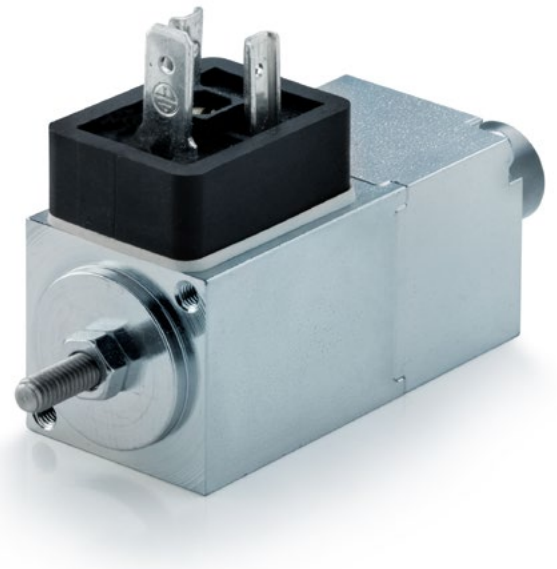

The **LHP025055** is a linear solenoid in closed design with an edge dimension of 25 mm. The series is preferably used for smallest installation volume and high force requirements. The fast-acting linear solenoid can be operated pulling or pushing; the stroke movement is achieved by electromagnetic force from stroke start position to stroke end position. The retraction is effected by an optionally integrated return spring. The mounting is provided at the front end.

The LHP025055 can be mounted in any position; the force transfer is axial.

The standard model has lead wires and protection class IP40. The standard coil voltage is 24V DC.

Other voltages are available on request. The modular design allows to equip the LHP025055 with further options, see options for LHP025055. The solenoid can be mounted in any position; the force transfer is axial.

Dimension Drawing

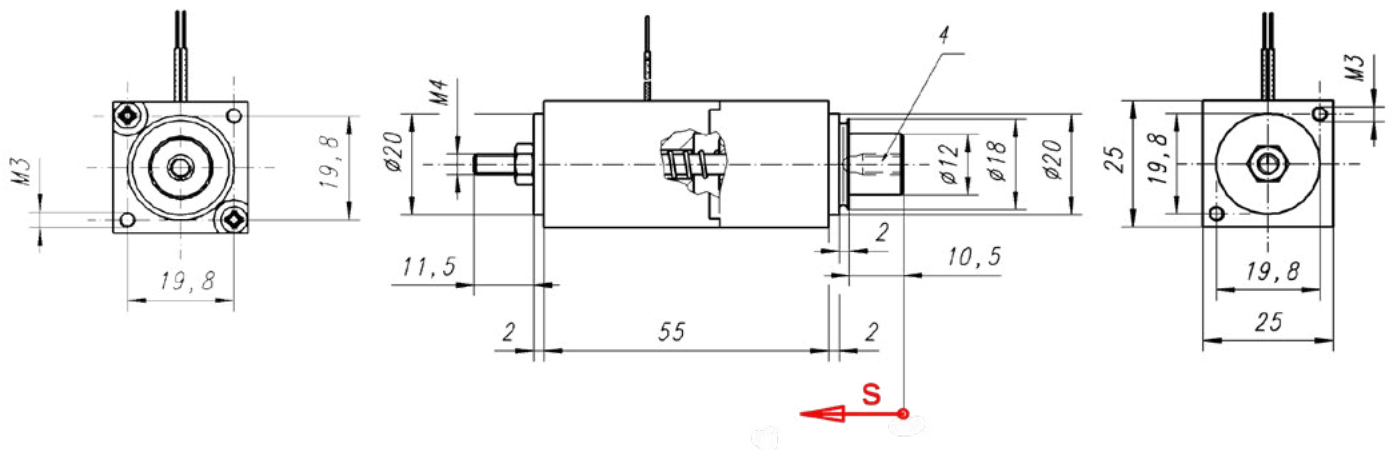

Technical Data

Type	LHP025055							
Duty cycle [%]	100		40		25		5	
Stroke s [mm]	5	10	5	10	5	10	5	10
Response time [ms]	57	74.8	56.4	76.4	98.2	115.2	73.4	88.8
Release time [ms]	37	48.4	36.4	46.4	34.2	42.8	30	39.8
Stroke movement [Ncm]	2.9	3.4	4.7	5	7.2	8.5	14	14.7
Rated power [W]	11		20.7		25.1		82.7	
Armature weight [kg]	0.035							
Solenoid weight [kg]	0.23							
Thermal class	F							



Information of the possible adjustments to your application are available on request
+49 771 8009 3770 or sales-ims@kendrion.com

Stroke Force Curves

The power indicated is reached at 90% of the rated voltage. The solenoids can be installed in any position, but the force transfer should be in axial direction only. The values for the duty cycles are reference values and apply for rated voltage, warmed-up condition and load with 70% of the magnetic force of the device.

LHP025055 (Stroke 5 mm)

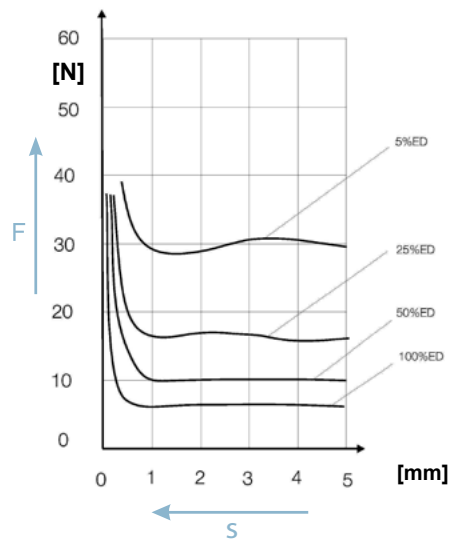

LLHP025055 (Stroke 10 mm)

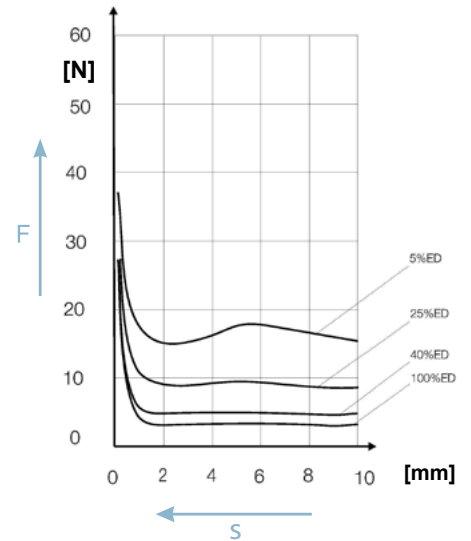

Options for the LHP025055

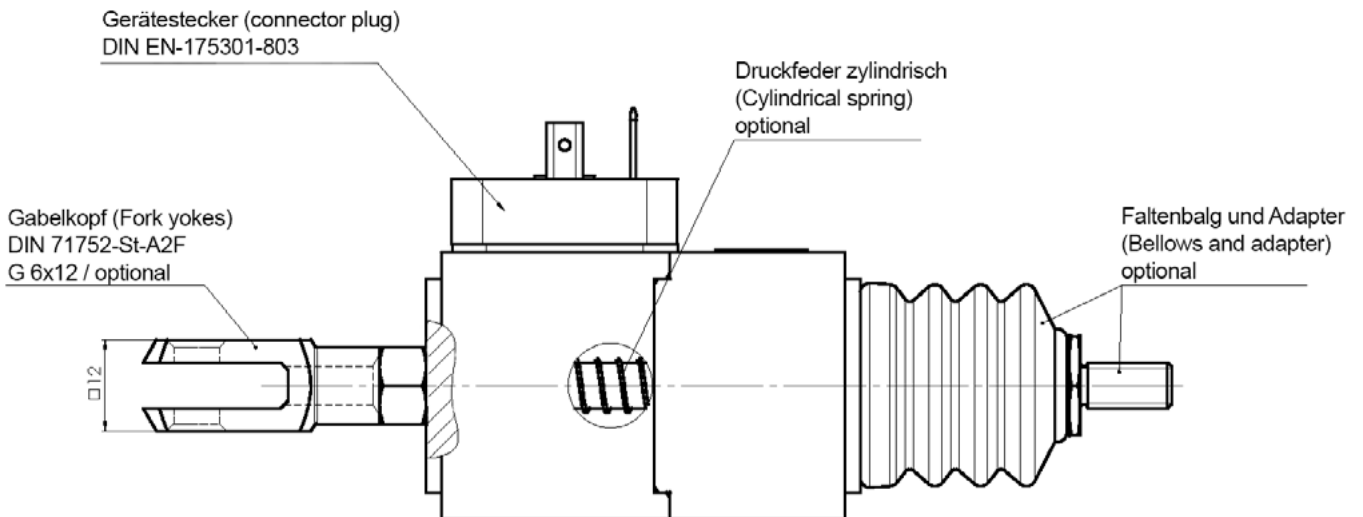



Accessories

Plug-in connector acc. DIN EN 175301-803 with / without bridge rectifier depending on the voltage

The 2-pole plug-in connector with protective lead is a connection specially designed for electro-magnetic devices.

The cable outlet can be rotated 4 x 90° by inserting the contact carrier accordingly.

After attaching the plug-in connector to the pin plate of the device plus sealing it is secured with a machine screw supplied. This guarantees an exact seal of the combination and prevents the plug-in connector from being accidentally detached under vibration.

A cable gland Pg 11 (material no. 430006) serves to seal the cable. The contact elements are suitable for connecting-wire cross sections of up to 1.5 mm². Air clearance and leakage paths acc. VDE 0110.



Model

- Type 430006 without integrated bridge rectifier
- Type 430001 with integrated bridge rectifier

Technical Data

- Insulation class C
- Protection class IP 65 (in plugged in and secured condition)
- Plug load 2.5 A / 10 A

Dimension Drawing

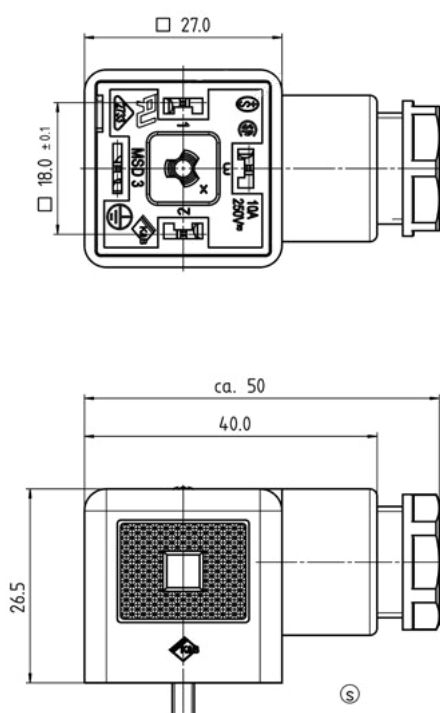



Fork head acc. DIN 71752

Fork heads are used to connect all types of linear solenoids to force transfer elements such as levers, push bars, valve flaps and sliding dampers. In many cases they enable rapid connection during assembly and also quick replacement of wear and spare parts.

The types without ES-bolt achieve the force transfer between fork head and customer application by a cylindrical pin with common safety elements.

The fork heads are electrogalvanised.

Installation Note

With its thread the fork head is screwed to the pull or push bar of the linear solenoid and secured with a locknut.



Dimension Drawing

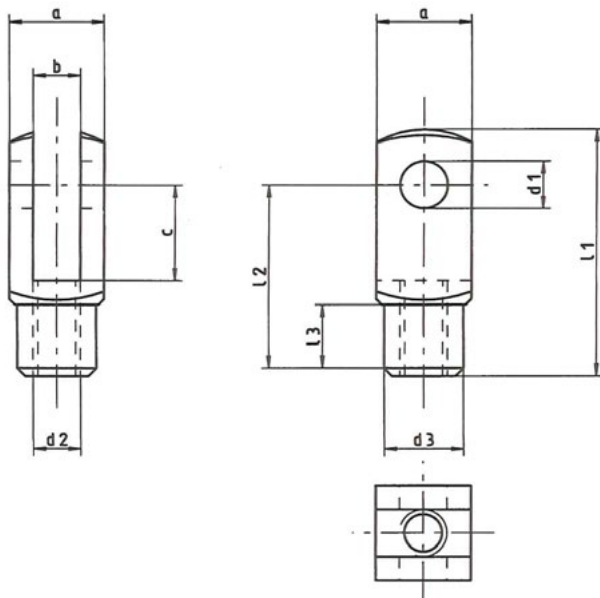

Technical Data

Designation	a	b	c	d1	d2	d3	i1	i2	i3
GK 1	8	4	8	4	M4	8	21	16	6
GK 2	10	5	10	5	M5	9	26	20	8
GK 3	12	6	12	6	M6	10	31	24	9
GK 4	16	8	16	8	M8	14	42	32	12
GK 5	20	10	20	10	M10	18	52	40	15
GK 6	24	12	24	12	M12	20	62	48	18

Snap-on fork pins acc. 71752

The use of a fork head with snap-on fork pin results in a quickly assembled and readily detachable connection (no tools required) between the linear solenoid and the component.

The spring clip ensures that the fork pin remains securely in position. The fork heads are electrogalvanised, the fork pins are electrogalvanised.



Thermal Classes

As shown in the table below thermal classes are classified according to DIN VDE 0580 / 07.2000 into insulation classes on the basis of their longterm thermal stability. Depending on the type our linear solenoids are manufactured in thermal classes E, B and F. If required by the application most devices can also be delivered in thermal class H.

Thermal class	Limit temperature °C	Limit overtemperature °C
Y	90	50
A	105	65
E	120	80
B	130	90
F	155	115
H	180	140

Protection Classes [IP]

Protection classes are indicated by a short symbol consisting of the two invariable code letters IP and two code letters for the degree of protection. The protection classes indicated are determined according to IEC 60529. They apply to protection against contact and against penetration of foreign substances. The second code letter applies to protection against penetration of water.

In case the protection class of e.g. the electrical connection deviates from that of the solenoid the protection class of the connection is indicated separately, e.g. housing IP 54, connection IP 00.

Code Letters Protection against contact and foreign substances	
0	no protection
1	protection against big foreign substances
2	protection against medium-sized foreign substances
3	protection against small foreign substances
4	protection against grain-shaped foreign substances
5	protection against dust deposit
6	protection against dust penetration

Code Letters Protection against water	
0	no protection
1	protection against vertical dripping water
2	protection against dripping water falling at an angle
3	protection against spray water
4	protection against splashing water
5	protection against flooding

Code Letters Protection against water	
6	protection against flooding
7	protection against immersion
8	protection against submersion

Rated Modes of Operation

Continuous operation is the operation during which the duty cycle is so long that the SteadyState temperature is reached.

Intermittent operation is the operation during which duty-cycle and currentless break alternate in regular and irregular intervals, the breaks being so short that the device cannot cool down to the reference temperature.

Short time operation is the operation during which the duty cycle is so short that the SteadyState time is not reached. The currentless break is so long that the solenoid cools down to the reference temperature.

Technical Terms Related to Electricity

The rated voltage (U_N) is the voltage with which the solenoid is operated in normal operation.

The rated power (P_N) is the power which results from the rated voltage and the rated current with DC solenoids of a coil temperature of 20°C.

The rated current (I_N) is the current which results from the rated voltage (U_N) and the resistance (R20) with a coil temperature of 20°C.

Technical Terms Related to Force

Magnetic force is the exploitable mechanical force reduced by the friction which is generated in stroke direction. The magnetic force is safely reached with 90% rated voltage and maximum warming. With rated voltage the listed values rise by approx. 20%.

Stroke force is the magnetic force which acts outside taking the respective component of armature weight into consideration.

Holding force is the magnetic force in stroke end position with DC-solenoids; with AC-solenoids it is the average value of the magnetic force periodically fluctuating with the alternating current in stroke end position.

Reset force is the force required to reset the armature into stroke start position after switching off the excitation current.

Relative duty cycle (% ED) is the ratio between duty cycle and cycle time in per cent. It is calculate according to the following formula:

$$\% ED = (\text{duty cycle} / \text{cycle time}) * 100$$

In order to calculate the relative duty cycle the preferred value of the cycle time acc. DIN VDE 0580 item 3.2.2 of 5 minutes is usually taken as a basis.

If the cycle time is irregular the relative duty cycle is determined from the ratio between the sum of the duty cycles and the sum of the cycle times over a longer period of operation.

The maximum values of the duty cycle must not be exceeded. If the relative duty cycle was determined and its value exceeds the permitted maximum value acc. DIN VDE the higher %-ED has to be selected into the range of which the duty cycle fits in. (Tables 1 and 2)

Playing time is the sum of the duty cycle and the currentless break. For DC single-stroke solenoids the playing time is max. 5 minutes = 300s. This equals 12 switchings / hour. The minimum playing time is limited by the actuation and release times in connection with the relative duty cycle. For a playing time of 300s there are maximum values for the duty cycle which must not be exceeded. In case the permitted duty cycle is exceeded a solenoid of the next higher relative duty cycle has to be selected.

If the duty cycle of 180s is exceeded the solenoid has to be selected for 100% duty cycle (continuous energization) or in special cases of the duty cycle calculated from the on/off ratio needs to be adapted by a proper selection of the magnetic coil. If the playing time is irregular the relative duty cycle is determined from the ratio between the added duty cycles and the added playing times over a longer **period of operation**.

By **playing sequence** we understand a single or periodically returning sequence of values for playing time.

Fuse Protection

Due to the differences in power consumption depending on the stroke an effective fuse protection of the AC solenoids is not possible. If some protection has to be provided please refer to the following formula:

$$I = \frac{\text{KVA open} \times 1000}{2 \times U} \quad [A]$$

A delayed fuse has to be used.

Frequency

Normally the coil is designed for a connection to 50 Hz. A solenoid with a rated frequency of 50 Hz may possibly be connected with the same voltage to a higher frequency. It has to be observed, however, that the magnetic force is reduced (appr. 30%). The use of a lower frequency is to be avoided as not only the force but also the heating increases (max. values 40 to 60 Hz). An adaptation to a lower frequency is possible on request, without a substantial modification of the magnetic forces specified in the list.

Relative duty cycle (% ED)	5	15	25	40	60	100
Permitted maximum duty cycle (s)	15	45	75	120	180	random

Table 1

Switching number (S / h)	12		120		300		600		1200		3000	
	t _{on}	t _{off}	t _{on}	t _{off}	t _{on}	t _{off}	t _{on}	t _{off}	t _{on}	t _{off}	t _{on}	t _{off}
Cycle time (s)	300		30		12		6		3		1.2	
% ED	t _{on}	t _{off}	t _{on}	t _{off}	t _{on}	t _{off}	t _{on}	t _{off}	t _{on}	t _{off}	t _{on}	t _{off}
5	15	285	1.5	28.5	0.6	11.4	0.3	5.7	0.15	2.85	0.06	1.14
15	45	255	4.5	25.5	1.8	10.2	0.9	5.1	0.45	2.55	0.18	1.02
40	120	180	12.0	18.0	4.8	7.2	2.4	3.6	1.20	1.80	0.48	0.72
60	180	120	18.0	12.0	7.2	4.8	3.6	2.4	1.80	1.20	0.72	0.48
100	random											

Table 2

Overview of Catalogue

Linear Solenoids



Classic Line

- single-stroke solenoids
- compact design
- individual fixing
- mono- and bistable version



High Performance Line

- square single-stroke solenoids
- high force with small installation space
- modular system
- short pull-in times



High Power Line

- round single-stroke solenoids
- high forces and stroke travels
- short switching times
- also reversible solenoids



Control Power Line

- control solenoids
- extremely fast switching
- short strokes
- precise switching

Electro Holding Magnets



Hahn CQ^{Line}

- door holding magnet
- design and functionality
- VdS, CE, EN 1155, EN 14637 tested
- great variety



Industrial Line

- industrial holding magnets
- high holding force with low power consumption
- compact design
- variable connections

Oscillating Solenoids



Oscillating Line

- vibratory solenoids
- wide product range for transportation of bulk material
- low wear and tear
- compact design



Elevator Line

- spreader solenoids
- especially designed for elevator brakes
- extremely high forces
- any mounting position



ATEX Line

- explosion-proof solenoids
- prevent the occurrence of sparks and light arcs
- dynamic and reliable switching



Locking Line

- locking solenoids
- high transverse forces
- integrated feedback of locking function
- compact design



System Line

- operated by AC
- extremely short activation times
- very high pull-in forces

Custom Solutions

- **Rotary solenoids**
- **Assemblies**
- **Customer-specific solutions**

Please contact us for special or customer-specific solutions.

Kendrion (Donaueschingen/Engelswies) GmbH
 Industrial Magnetic Systems
 Sales Team Donaueschingen and Engelswies
 Tel.: +49 771 8009 3770
 Mail: sales-ims@kendrion.com

Authorised, valued-added distributor

Australia & New Zealand



Powerbox Australia Pty Ltd

Sydney Head Office
4 Beaumont Road,
Mt Kuring-Gai, NSW 2080
Australia

 1800 251 380

 sales@powerbox.com.au

 powerbox.com.au

Powerbox Pacific Ltd

New Zealand Sales Office
1a Henry Rose Place,
Albany, Auckland
New Zealand 0632

 09 4158 320

 sales@powerbox.co.nz

 powerbox.co.nz